

## TOMOFLOW R100 TWO-PHASE FLOW ANALYSIS SYSTEM

The Tomoflow R100 system measures the flow rate and flow profile of one component of a two-phase mixture when both components are dielectric (insulating materials). It is therefore suitable for measuring the flow of mixtures such as solids and gases, oils and gases or solids and liquids, where the flow is non-uniform across the vessel or pipe. The measurement can be carried out either off-line from captured data or in real-time from on-line data and can be completely non-invasive for many material mixtures. The R100 equipment is most suitable for use in research environments such as flow measurement laboratories.

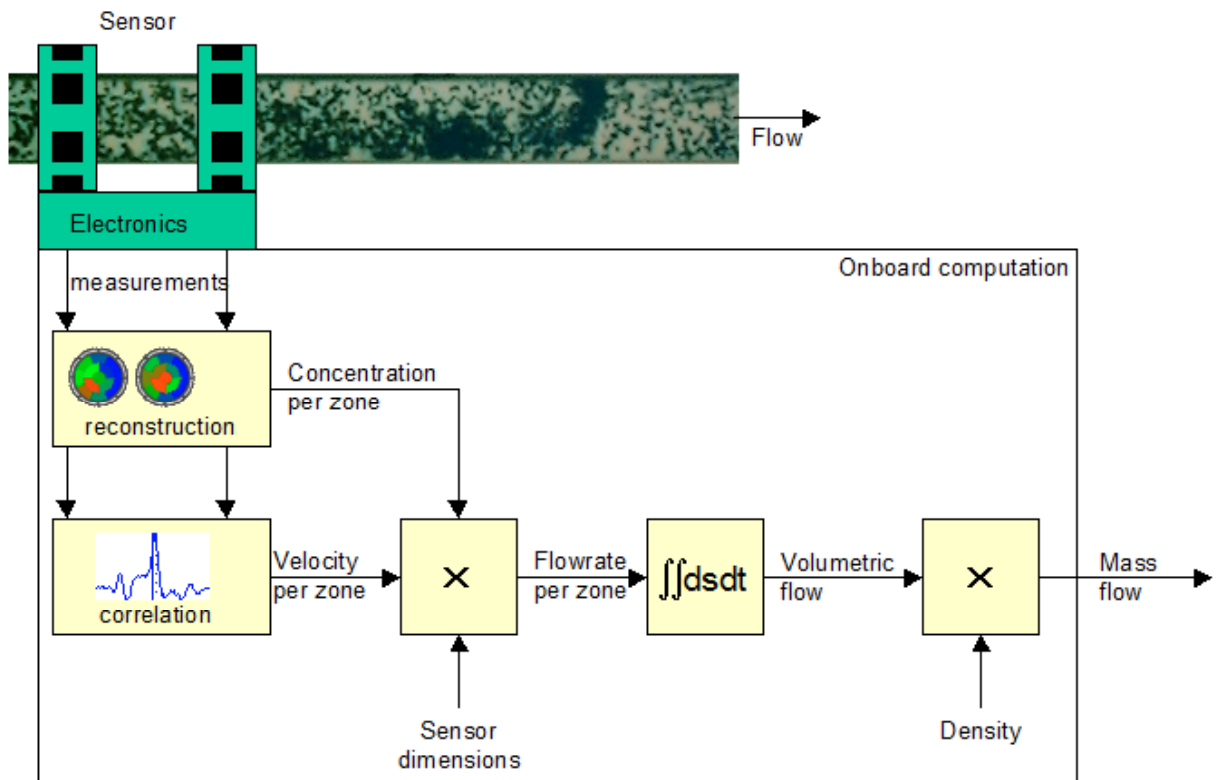

### Tomoflow measurement principle

The Tomoflow measurement principle is based on the use of high-speed twin-plane Electrical Capacitance Tomography. A multi-electrode capacitance sensor is used to produce sets of concentration profile frames at two axial pipe locations at high capture rates. Correlation techniques are used to convert these two sets of concentration profiles into velocity profiles across the pipe. The products of the concentration and velocity profiles are then integrated across the pipe area to produce an accurate measurement of volumetric flow.

The R100 system measures the velocity of the measured interfaces between the two dielectric materials. In the case of a weak mixture of granular solids and air, this will correspond to the speed of the granules and so the technique will measure the flow rate of the granules. However, in the case of a bubbly oil-gas mixture, the interface velocity will be that of the gas bubbles if the oil is the majority component of the mixture and so the measured flow rate will be that of the gas bubbles.

The range of measurable flow velocities depends on the particular flow-regime and the design of the capacitance sensor. The measurement principle requires the concentration profile at the first measurement plane to be sufficiently unchanged when it reaches the second measurement plane to allow correlation techniques to be used to extract the flow velocity. The achievable velocity resolution depends on the number of frames of data which can be captured during the time taken for the flow to move between the two sensing planes.

If the flow is reasonably stable, the two concentration profiles will be similar at the two sensing planes even if they are widely separated, allowing a relatively large number of data frames to be captured and successfully correlated, which means that relatively high flow velocities can be measured with reasonable resolution. However, if the flow regime is more chaotic, the sensing planes will need to be more closely spaced to ensure that the concentration profiles are sufficiently similar to be correlatable and this will limit the highest flow velocities that can be measured in practice.

The maximum measurable flow rate will also depend on the number of sensing electrodes used at each measurement plane. A larger number of electrodes will increase the accuracy of the concentration measurement but will also reduce the maximum frame capture rate. Conversely, a smaller number of electrodes will produce less accurate concentration profile measurements but data can be captured at higher frame rates. Consequently, there is a trade-off between the number of sensor electrodes, and the resolution of the concentration and velocity measurements. Practical capacitance sensors for flow measurement currently have between four and 12 electrodes located around the pipe circumference at each measurement location.

A complete flow measurement system consists of a twin-plane guarded multi-electrode capacitance sensor, a multi-plane capacitance measurement controlled by a personal computer and a comprehensive suite of data capture and analysis software.

The Tomoflow technology has a number of unique advantages compared with other flow measurement techniques:

- Flows can be measured provided the imaging system can distinguish between the two phases. Most other measurement techniques require the two flow components to be separated before measurements can be made.
- It can be non-invasive and therefore will not disturb the flow pattern. Consequently it can be used where abrasive flows would destroy other flow sensors.
- The lack of internal features or moving parts means that there is no extra pressure drop across the sensor and also results in low maintenance costs.
- As the velocity is calculated in each zone across the flow cross-section, the measurement does not suffer from the gross errors exhibited by multiphase flow meters which rely on calculating an average velocity figure over the pipe cross-section.

For further information, please contact us at the address below, or visit our internet web site at : **[www.tomoflow.com](http://www.tomoflow.com)** which contains comprehensive sales and application data.

---

#### **TOMOFLOW LTD**

**West Hembury Farm, Askerwell, Dorchester. DT2 9EN UK**  
**Phone/Fax +44-(0)-1308-485697**  
**email: [enquiries@tomoflow.com](mailto:enquiries@tomoflow.com) Website: [www.tomoflow.com](http://www.tomoflow.com)**